

Q1. Needle	3
Q1-1. What kind of needle should I use?	3
Q1-2. When should I replace the needle?	3
Q2. Thread	3
Q2-1. What kind of thread should I use for the needle thread (upper thread)?	3
Q2-2. What kind of thread should I use for the bobbin thread (lower thread)?	3
Q2-3. How should I trim the needle thread (upper thread)?	4
Q2-4. How should I trim the bobbin thread (lower thread)?	4
Q2-5. How should I wind the bobbin evenly?	4
Q2-6. There is not enough thread on the bobbin.	4
Q3. Fabric	5
Q3-1. How should I embroider a towel ?	5
Q3-2. How should I embroider on denim ?	5
Q3-3. How should I embroider on stretchy jersey or smooth knit fabric?	5
Q3-4. How should I embroider on fake fur ?	5
Q3-5. How should I embroider on fine fabric such as organdy ?	5
Q3-6. How should I embroider a fabric that hard to attach to the hoop?	6
Q3-7. How should I get rid of the hoop marking on a fabric?	6
Q3-8. How should I embroider the edge of fabric?	6
Q3-9. How should I make and use a hooping fabric?	6
Q3-10. How should I embroider a small fabric?	8
Q3-11. How should I embroider a narrow piece of fabric?	9
Q3-12. How should I use a stabilizer ?	10
Q4. Other FAQ	11
Q4-1. I want better looking finish on the rear side of the embroidery design.	11
Q4-2. Will there be any more designs with this machine?	11
Q4-3. How should I adjust the position of the hoop?	11

Q4-4. How long does it take to finish an embroidery design?..... 12
Q4-5. How can I combine the embroidery designs to make a larger design?..... 12
Q4-6. How should I check the size and the number of colours for the embroidery design? 14
Q4-7. How can I check the next thread colour? 15
Q4-8. How can I embroider original design created using the AcuSketch app? 15
Q4-9. How can I embroider Japanese characters (Kanji/Hiragana/Katakana)?..... 16

Q1. Needle

Q1-1. What kind of needle should I use?

A 1-1. The blue tip needle (Part #813404013) that come with the embroidery machine is recommended. You can also use Organ needle HA x 1 #11, HA x 1SP #11. Contact the store from which the machine was purchased for more details.

Q1-2. When should I replace the needle?

A 1-2. Replace the needle under the following conditions:

- The needle is bent.
- The needle is getting dull.
- The thread breaks too often.
- The sewing noise becomes loud.

Q2. Thread

Q2-1. What kind of thread should I use for the needle thread (upper thread)?

A 2-1. JANOME Polyester, FUJIX KING STAR Polyester, Gutermann SULKY Rayon, Isacord Polyester, MADEIRA Rayon, Mettler Poly sheen, Robison-Anton Polyester, Robison-Anton Rayon and Wonderfill Splendor Rayon are recommended.

※ Do not use poor quality threads. Using those threads may cause malfunction of the embroidery machine.

Q2-2. What kind of thread should I use for the bobbin thread (lower thread)?

A 2-2. #90, 205 (dtex), 185(D) 100% Polyester spun thread 100% is recommended.

※ Use the thread described above for the bobbin thread to achieve the best result.

Q2-3. How should I trim the needle thread (upper thread)?

A2-3. Trim the needle thread as close to the end of the seam as possible.

- ※ You do not have to cut the short jump threads on embroidery designs.



Leaving jump threads is recommended.

Q2-4. How should I trim the bobbin thread (lower thread)?

A2-4. Leave approximately 1 cm (3/8") tail on the bobbin thread.

- ※ Knot the end of threads or use a glue to prevent fraying.

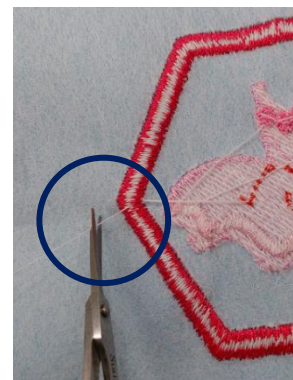

Q2-5. How should I wind the bobbin evenly?

A2-5. Align the slit of the bobbin and the small projection on the bobbin winder spindle when inserting the bobbin.

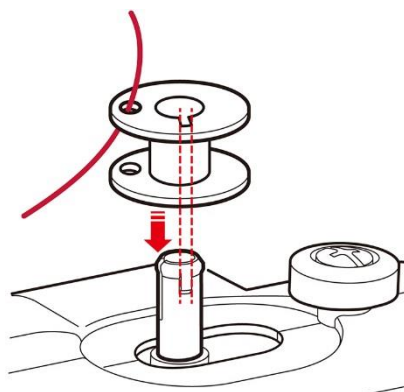

Q2-6. There is not enough thread on the bobbin.

A2-6. Bobbin winding stops automatically after about 90 seconds.

If the amount of the thread on the bobbin is not enough, press the start/stop button again to continue the winding. Press the start/stop button if the bobbin is wound enough.

Q3. Fabric

※ Always test sew before starting embroidery.

Q3-1. How should I embroider a towel ?

A 3-1. Attach a water soluble sheet on the towel, and embroider.

Embroidering on the towel without using a water soluble sheet may cause a malfunction of the embroidery machine or fraying of the towel. Use a water soluble sheet for better quality embroidery.

※ Do not embroider on a thick towel. The thickness of the towel should be about 0.3 (1/8") cm or less.

Q3-2. How should I embroider on denim ?

A 3-2. Use a soft denim 12 ounces or less. Do not embroider over multiple denim layers.

Q3-3. How should I embroider on stretchy jersey or smooth knit fabric?

A 3-3. Attach a stabilizer on the wrong side of the fabric (refer to Q3-12).

Be careful not to attach the fabric too tight on the hoop.

※ If the jersey or smooth knit on the hoop is too tight, the embroidery designs on the fabric will be distorted. Use a hooping fabric for better result.

Q3-4. How should I embroider on fake fur ?

A 3-4. Brush the fake fur in one direction. Attach a water soluble sheet on the fake fur, and embroider. Remove or soak the water soluble sheet after embroidery.

Q3-5. How should I embroider on fine fabric such as organdy ?

A 3-5. Using a water soluble stabilizer is recommended. Attach a water soluble stabilizer on the fine fabric and embroider.

Test sew and tighten the needle thread tension dial as necessary.

(Some fine fabrics are very hard to embroider and using a water soluble sheet may not work well.)

Q3-6. How should I embroider a fabric that hard to attach to the hoop?

A 3-6. Use a hooping fabric.

Refer to Q3-9.

Q3-7. How should I get rid of the hoop marking on a fabric?

A 3-7. Iron the fabric after the embroidery.

Use a hooping fabric for un-ironable fabrics.

Refer to Q3-9.

Q3-8. How should I embroider the edge of fabric?

A 3-8. Use a hooping fabric.

Refer to Q3-9.

Q3-9. How should I make and use a hooping fabric?

A 3-9. To make a hooping fabric, follow the steps below.

How to make a hooping fabric

○Requirements:

•Thick sheeting fabric : 20cm×20cm (8"×8")

•Iron-on stabilizer : 20cm×20cm (8"×8")

① Attach the iron-on stabilizer to the thick sheeting fabric with an iron.

② Draw the centre lines on the fabric and cut out the square 11cm×11cm (4.4"×4.4").

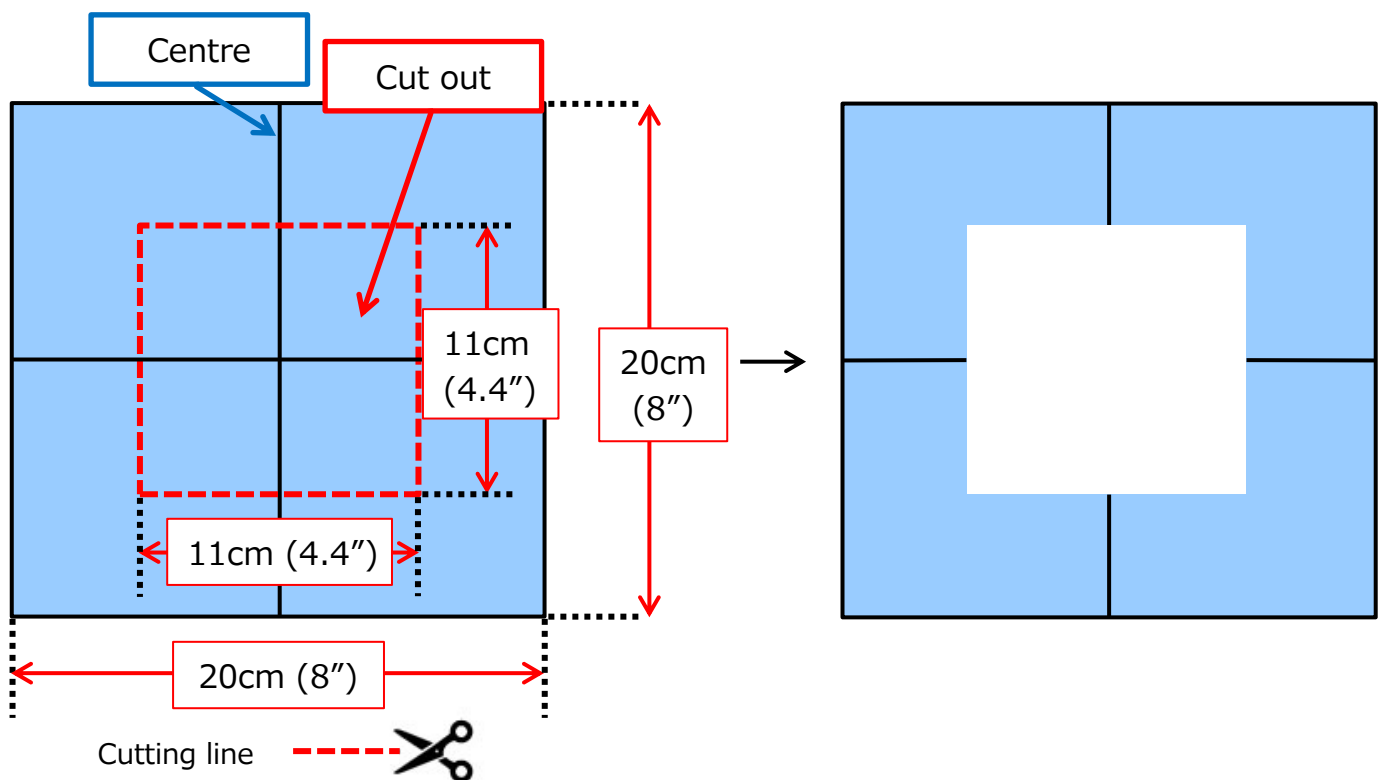
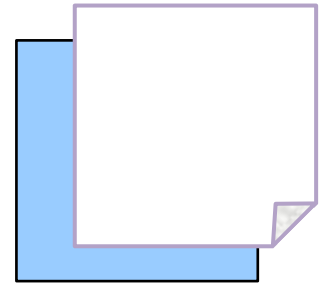

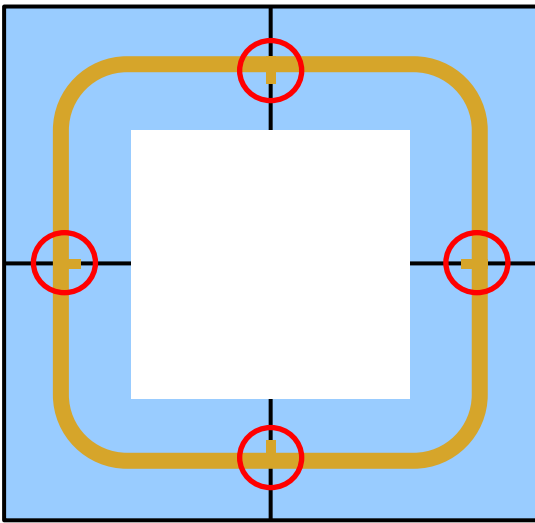

How to use the hooping fabric

- ① Align the centre lines of the fabric with the positioning lines of the hoop and attach.

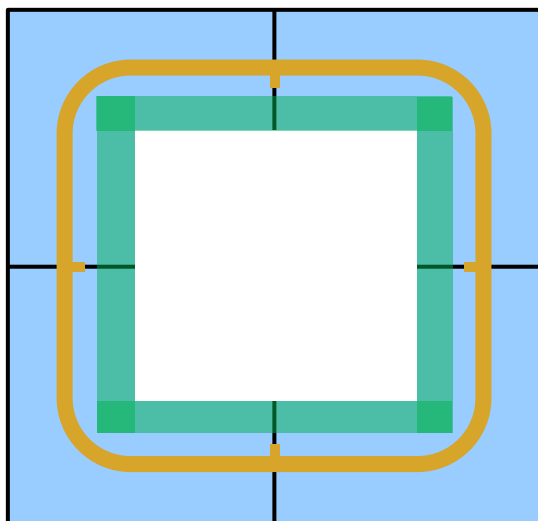

- ② Apply the double-sided tape for temporary attachment around the edge of the inner square. Draw the centre lines on the fabric attached to the stabilizer, and attach the fabric to the hooping fabric matching the positioning lines of the hooping fabric.
- ③ Lay the template on top and check the positioning.



 Double-sided tape

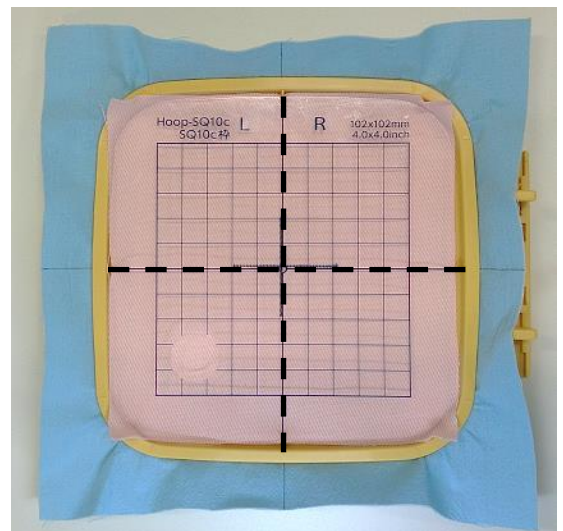

 Embroidery fabric

Q3-10. How should I embroider a small fabric?

A 3-10. Make the hooping fabric for the small fabric. Use the hooping fabric to match the smaller fabric.

① Make the hooping fabric for the small fabric.

Cut out a square hole 1cm (3/8") smaller than the embroidery fabric.

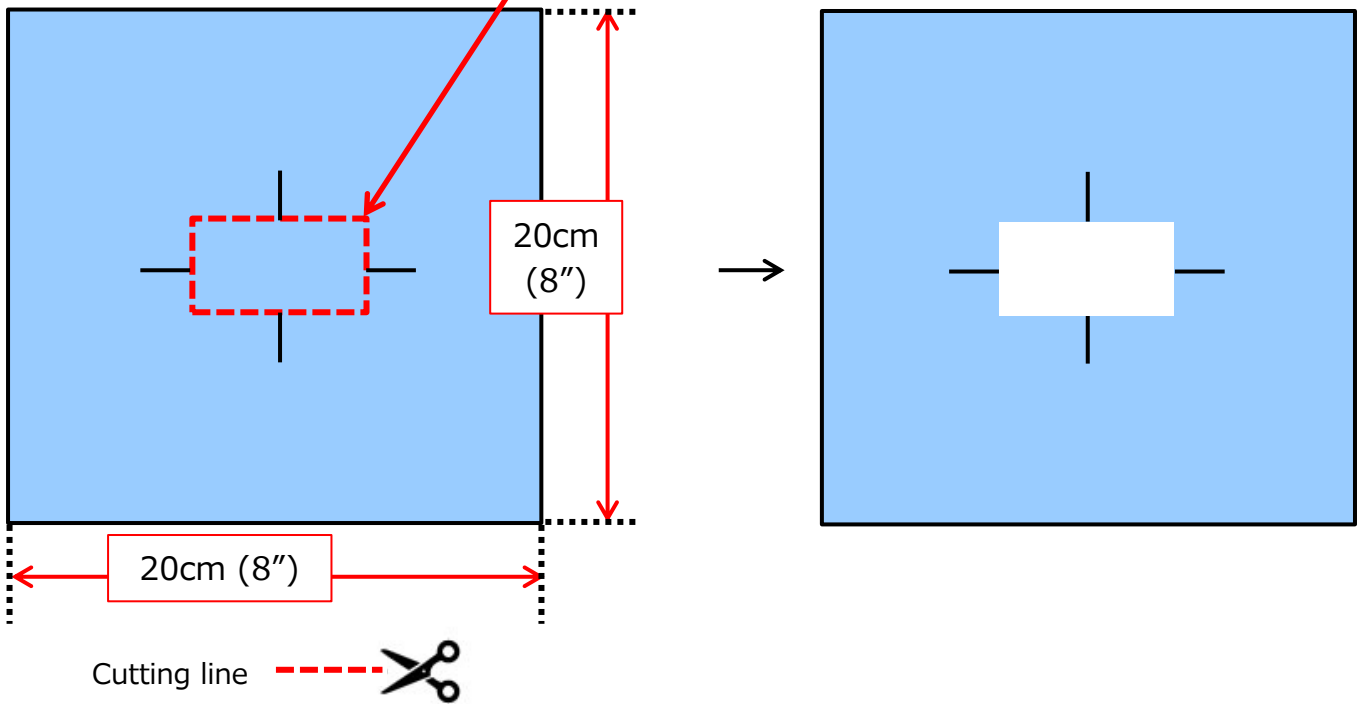

② Apply the double-sided tape for temporary attachment around the edge of the inner square.

③ Draw the centre lines on the fabric attached to the stabilizer, and attach the fabric to the hooping fabric matching the positioning lines of the hooping fabric.

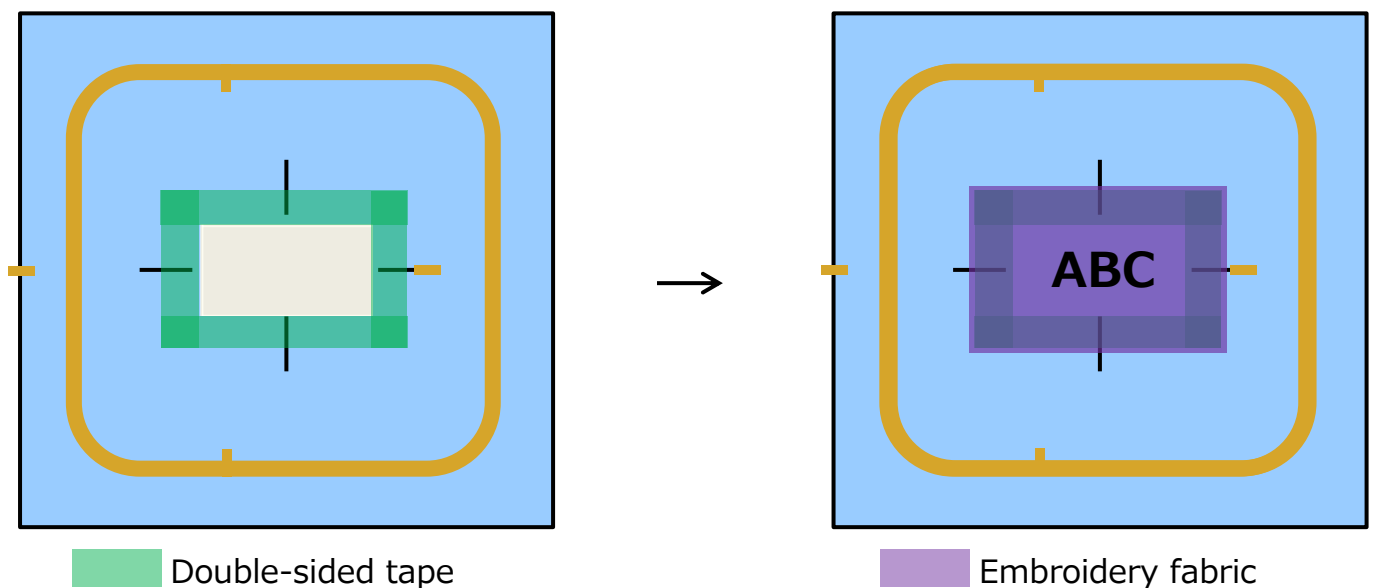

Q3-11. How should I embroider a narrow piece of fabric?

A 3-11. Attach the stabilizer on the rear side of the hooping fabric and place the embroidery fabric on the right side.

※ Use a water-soluble stabilizer if the fabric is transparent.

① Place the stabilizer on the rear side of the hooping fabric and attach it to the hoop.

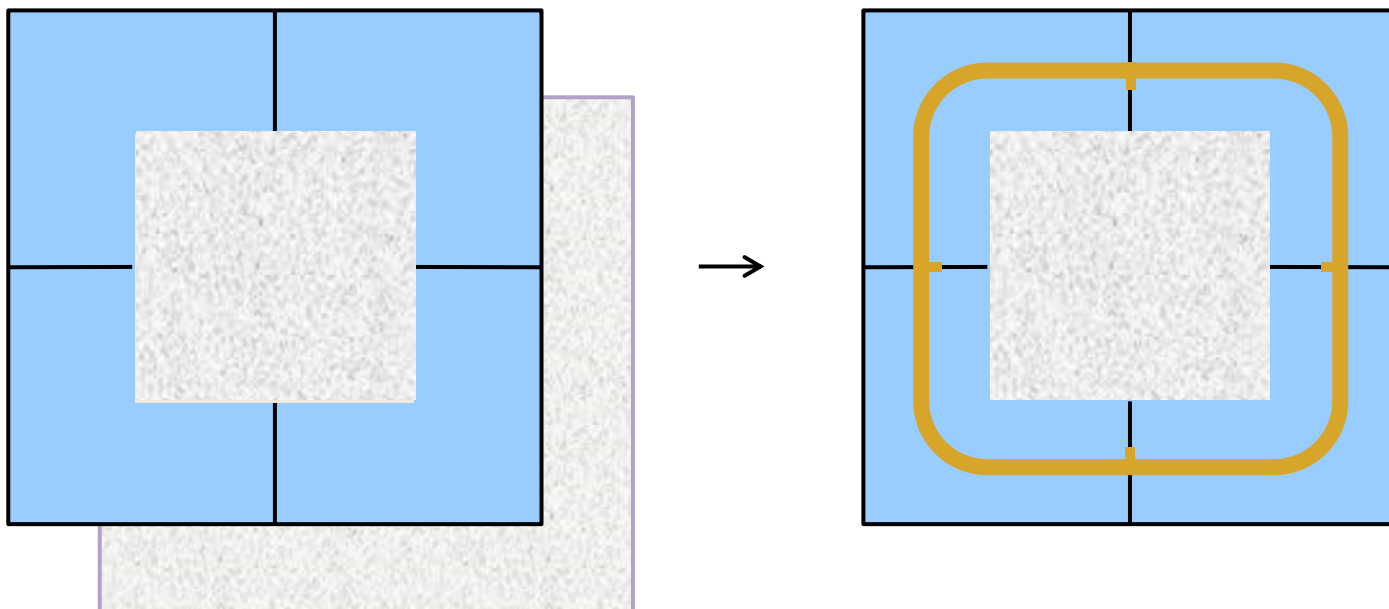

② Apply the double-sided tape to the hooping fabric.

③ Attach the embroidery fabric to the hooping fabric.

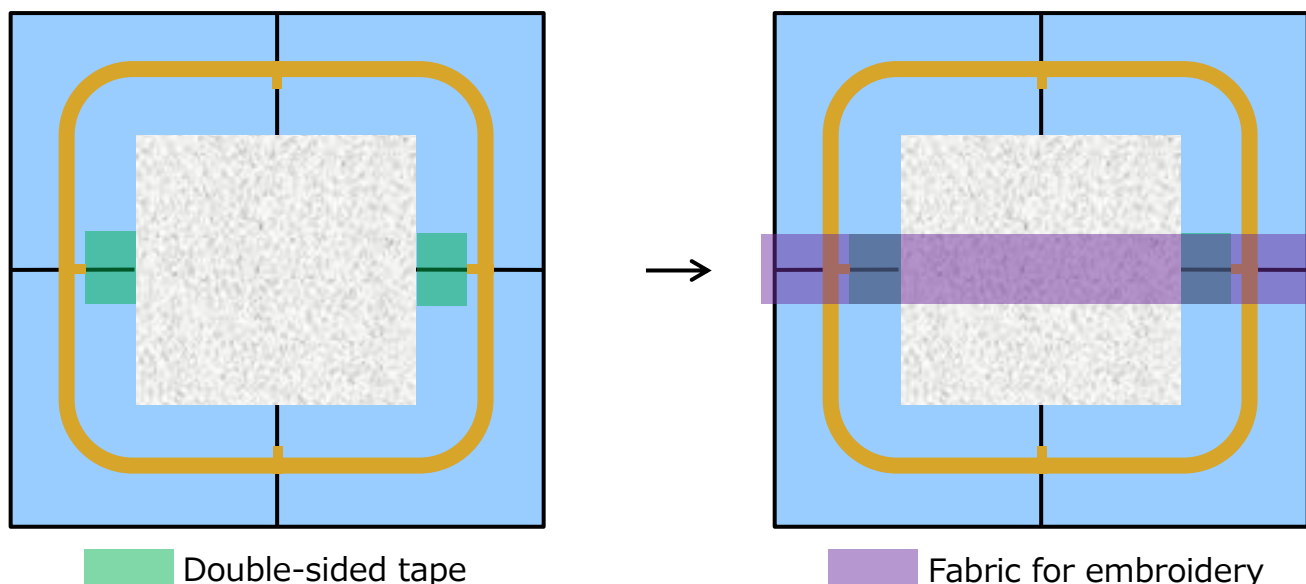

Double-sided tape

Fabric for embroidery

NOTE) Do not apply the double-sided tape to the embroidery area. This may cause a malfunction of the embroidery machine.

Q3-12. How should I use a stabilizer ?

A3-12. To create the best quality embroidery, attach a stabilizer to the wrong side of the fine fabric.

Stabilizer usage varies depending on the fabric.

Refer to the following chart.

- Iron-on
Adhesive with an iron to the wrong side of the fabric.
Nonwoven type: Remove the nonwoven type after the embroidery.
Woven type: Use the woven type if it is not necessary to remove the stabilizer.
- Water-soluble stabilizer
Use water-soluble when you do not want to leave the stabilizer.
Prepare a washable fabric. Wash the fabric once after embroidery.
- Water-soluble sheet
A water-soluble sheet is not a stabilizer.
Place the water-soluble sheet on the fabric when embroider towel, microfiber or fake fur fabrics.

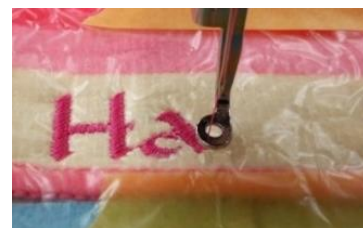

Fabric	Fabric			
	Right side	Wrong side		
	Water-soluble sheet	Iron-on ^{※1}		Water-soluble stabilizer
Nonwoven type		Woven type		
Felt	Not necessary	✓ (Recommended)	✓	✓ Do not use on wool
Towel Micro fiber	✓ (Recommended)	✓ ^{※2} (Recommended) Do not attach		✓
Fake fur	✓ (Recommended) Remove	✓ (Recommended) Do not attach	✓ Do not attach	✓

	without soaking			
Fine fabric (Organdy, etc.)	✓	✓ Do not attach. Remove it carefully.		✓
Ordinary fabric (Cotton, etc.)	Not necessary	✓	✓	✓
Stretch fabric (jersey, smooth knit, etc.)	✓	✓	✓ Will not stretch or shrink	
			Do not use stretch stabilizer	

- ※1 To attach an iron-on stabilizer, refer to the stabilizer manual.
- ※2 Attaching stabilizers to a towel or microfiber may damage the fabrics when removing. Hooping fabric is recommended for towel and microfiber fabrics.

Q4. Other FAQ

Q4-1. I want better looking finish on the rear side of the embroidery design.

A4-1. Use the same thread for the needle and bobbin threads.

Q4-2. Will there be any more designs with this machine?

A4-2. The addition of more designs is planned.

Q4-3. How should I adjust the position of the hoop?

A4-3. Press the jog buttons to adjust the position of the hoop.

Q4-4. How long does it take to finish an embroidery design?

A4-4. The embroidery machine sews 1000 stitches in 3 to 4 minutes. (The time for changing thread is not included.)

Q4-5. How can I combine the embroidery designs to make a larger design?

A4-5. You can connect embroidery designs by using a template and template sheets.

Example : How to connect the border designs horizontally

- ① Print out the template sheet from the on-line help. Cut the template sheet to the size of the design.
- ※ Print the template sheet at "Actual size". Use a semi-opaque paper for the template sheet.

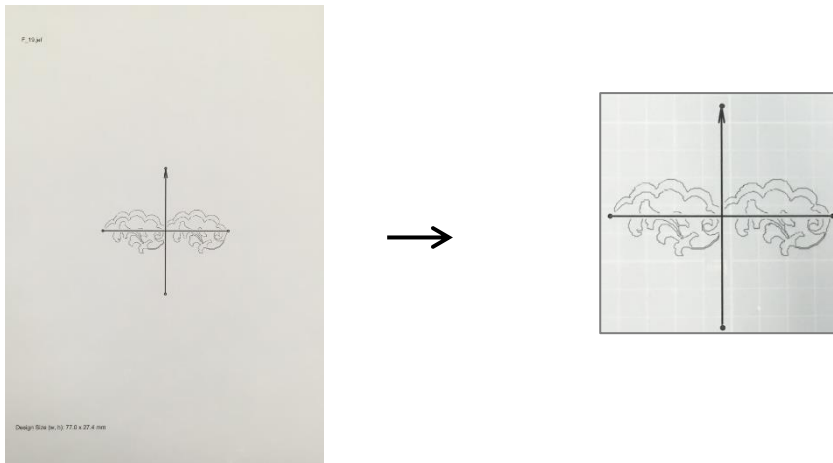

- ② Draw a horizontal line on the fabric where the centre of the design will be.
- ③ Align the horizontal line on the fabric with the horizontal line on the template sheet, and mark the end points for a vertical line. Connect the points to draw the vertical line.
- ※ A water-erasable marker works best.



- ④ Match the centre lines of the fabric and the centre lines of the template sheet, and attach the fabric to the hoop.

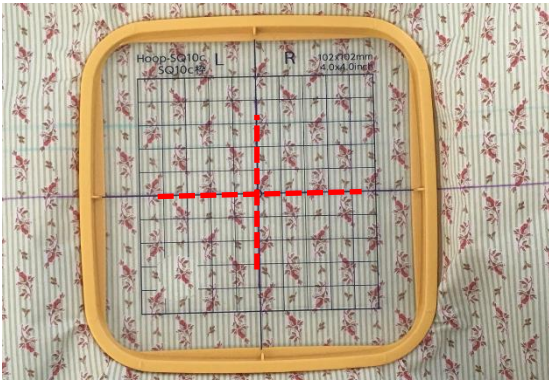

- ⑤ Attach the embroidery hoop to the machine and adjust the hoop position so that the needle drops at the intersection of the centre lines.



※ Raise the needle before pressing jog keys.

- ⑥ After finishing the first design, remove the embroidery hoop from the machine and remove the fabric from the hoop.
- ⑦ Place the template sheet to connect the designs. Mark the end points of the vertical centre line for the second design.

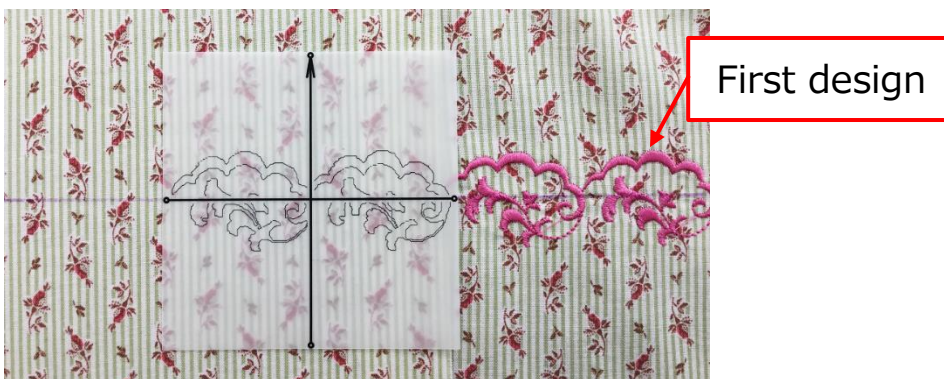

- ⑧ Draw the vertical line as described in step ③.

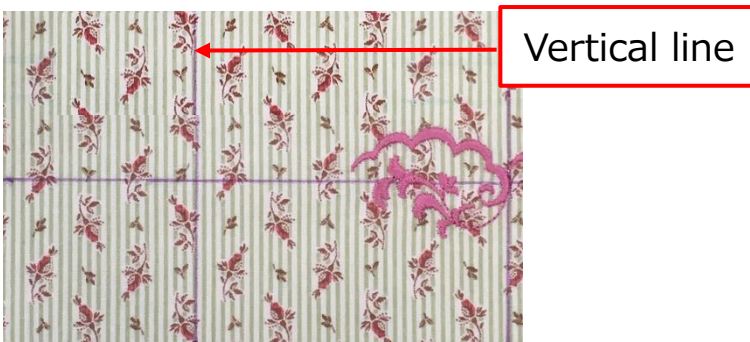

- ⑨ Match the centre lines on the fabric to the centre lines on the template sheet, and attach it to the hoop as described in step ④.
- ⑩ Attach the embroidery hoop and adjust the hoop position so that the needle drops at the intersection of the centre lines as described in step ⑤.
- ⑪ After finishing the second design, remove the embroidery hoop from the embroidery machine and remove the fabric from the hoop.
- ⑫ Repeat steps ⑦ to ⑪.



Q4-6. How should I check the size and the number of colours for the embroidery design?

A 4-6. You can check the size of the embroidery design, the number of colours and the number of total stitches on the app “dot Customizer”. You can also check the design size by printing the template sheet at its actual size.

Tap the  icon on Collection selection screen.

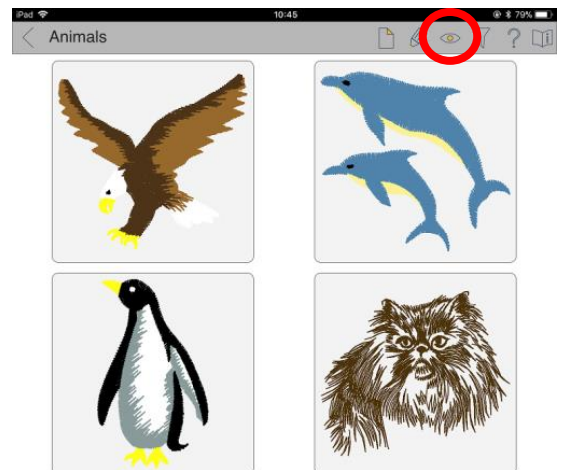
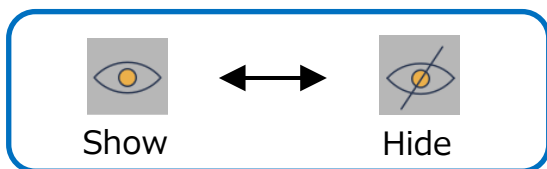

Design name: A_02

Design size: 47.2x44.9 mm

Number of colours: 3

Total stitch number: 1650

Q4-7. How can I check the next thread colour?

A 4-7. You can check the colour of thread on the “Real-time screen” in the “dot Customizer” app.

- ① The confirmation screen appears when embroidery data is sent to the embroidery machine.
- ② You can check the current sewing situation, current colour and next colour.

① Confirmation screen

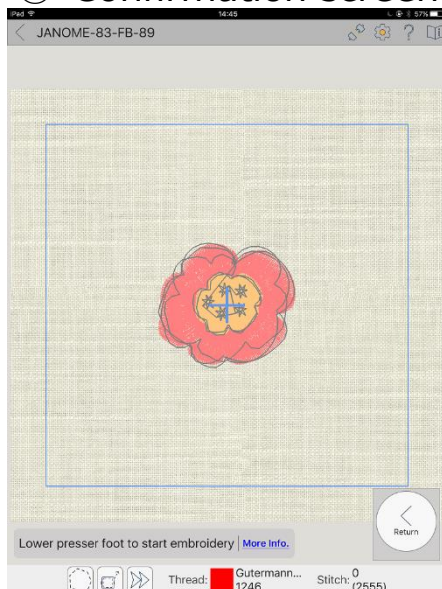

② Real-time screen

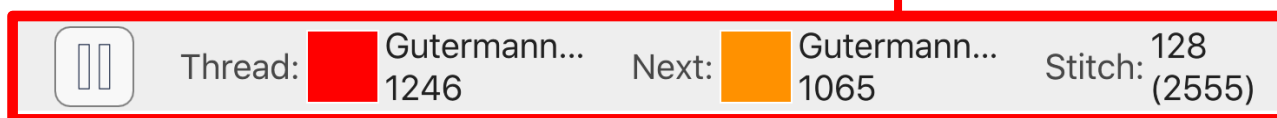
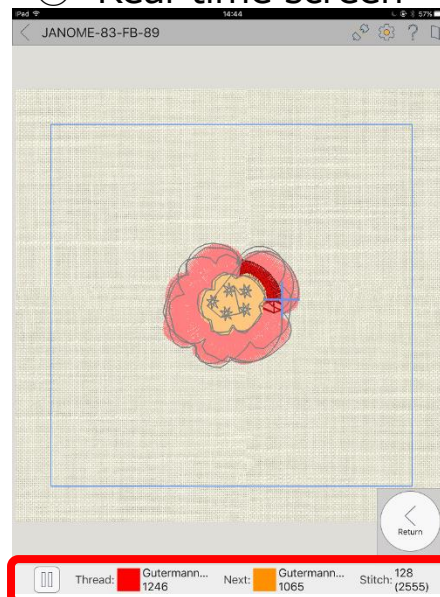

You can display the real-time screen by tapping the icon on the lower right corner.

Q4-8. How can I embroider original design created using the AcuSketch app?

A 4-8. Use Single stitch for the embroidery.

Set the stitch length to 2 mm or more.

Be careful not set the stitch length too small when using triple stitch, zigzag stitch, or stem stitch.

- The AcuSketch app is available only for iPad. It is not available for iPhone or Android.
- Be careful not to embroider over other embroidery designs. This applies a large load to the embroidery machine.

Q4-9. How can I embroider Japanese characters (Kanji/Hiragana/Katakana)?

A4-9. Set the keyboard as follows and enter Japanese characters. (Kanji/Hiragana/Katakana).

- ① Add Japanese to the keyboard.
 - ② Select 楷書 font from the font selection edit screen on the app.
 - ③ Enter the Japanese characters you want.
- ※ You can type Hiragana directly using the Japanese Kana keyboard.

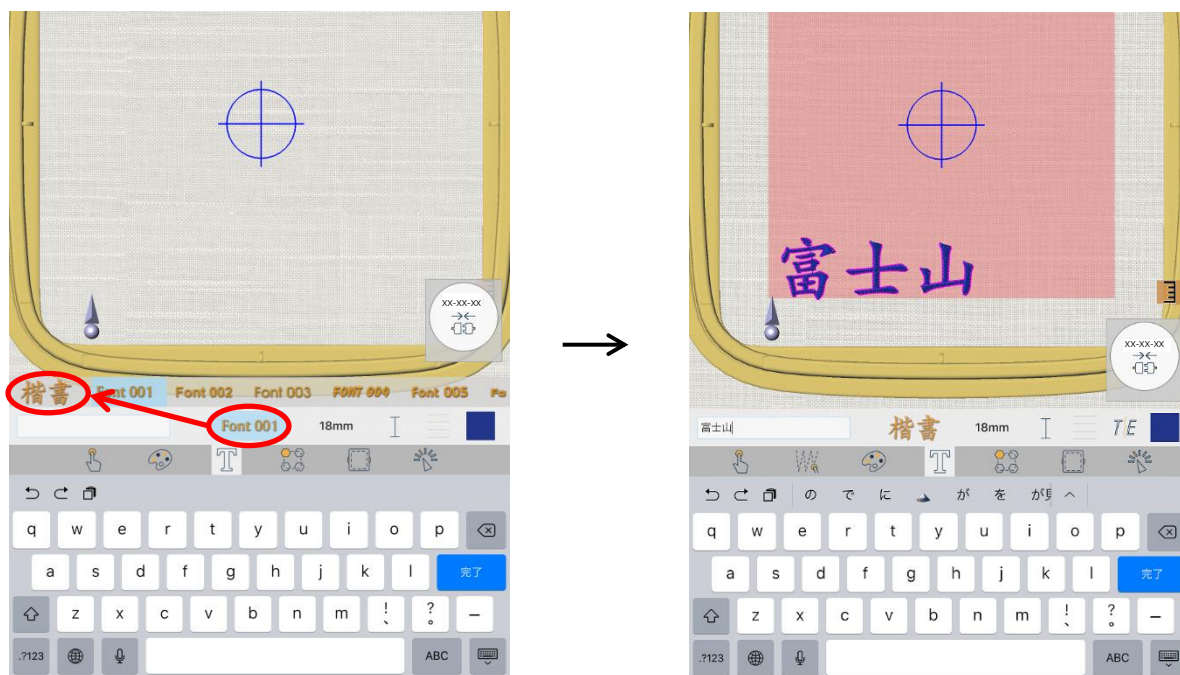

How to enter Mt.Fuji : 「fujisann」→ ふじさん/富士山
Wind : 「kaze」→ かぜ/風